



Series II

2-SPEED

13" 110V
15" 110V
17" 110V

CMCY-13-2
CMCY-15-2
CMCY-17-2

19" 110V
20" 110V

CMCY-19-2
CMCY-20-2

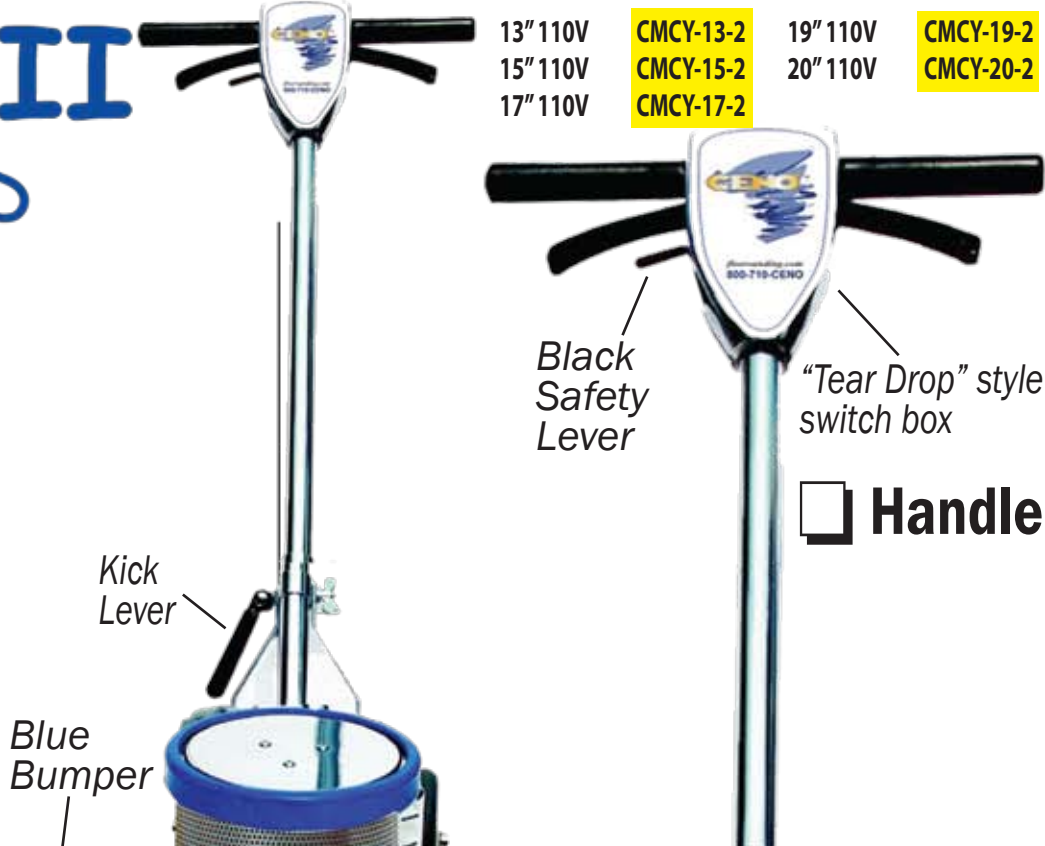

Handle

Dust Control



CM271
Vacuum Plate
Handle Hose Adapter
Floating Dust Ring
Port & Nut



CM500
Sandpaper Driver
Handle Hose Adapter
Floating Dust Ring
Port & Nut



CM501
Pad Driver
Handle Hose Adapter
Floating Dust Ring
Port & Nut

Motor



Enclosed motor with 3 holes, ventilation holes around the motor, blue bumper on top

CENO GROUP • 12221 Carlsbad St., Houston, TX 77085 • 800-710-2366 • Fax: 713-551-8456 • sales@floorsanding.com

For easier and faster ordering, please verify your model by checking the above pictures.

ITEM #	DESCRIPTION	PART #
1	SWITCH BOX BACK	OPA-104
2	HANDLE TUBE SCREW	OPB-23
3	SWITCH BOX CLOSING SCREW	OPB-21
4	STRAIN RELIEF CLIP	OPM-213
5	GROUND WIRE SCREW	OPB-68
6	RUBBER SPACER	OPM-218Y
7	HAND GRIP	OPM-218CN
8	HANDLE TUBE INSERT	OPM-247
9	HANDLE TUBE ASSEMBLY	OPM-206
10	CABLE HOOK SCREW	OPB-2
11	CABLE HOOK	OPA-164
12	SLIDING COLLAR	OPA-111
13	CAM WASHER	OPB-37
14	CAM LOCK WING NUT	OPB-25
15	CAM SPLIT WASHER	OPB-39
16	BENT BRACE	OPM-216
17	YOKE BOLT	OPB-18A
18	YOKE NUT	OPB-19
19	HANDLE TUBE CABLE	OPG-16
20	BLACK RUBBER CABLE CONNECTOR	OPM-249
21	CABLE GROMMET	OPB-63
22	RECTANGULAR HOLE CAM WASHER	OPB-67
23	COMPLETE CAM ASSEMBLY	OP-CCA
24	50' POWER CABLE 14/3 YELLOW	OPG-14-50-Y
25	SWITCH MOUNTING PLATE	OPG-30-B
26	SWITCH PLATE SCREW	OPB-1
27	INT. TOOTH LOCK WASHER	OPB-35
28	INSULATED FLAG WIRE CONNECTOR	OPG-48
29	ON-OFF SWITCH AND PLATE ASSEMBLY	OPG-30-AB
30	LOCK WASHER	OPB-33
31	TRIGGER RETURN SPRING	OPG-30-CT057
33	SWITCH BOX FRONT	OPA-103
34	WIRE CONNECTOR	OPG-47
35	TRIGGER	OPA-105
36	16" CROSSBAR	OPM-212
37	SAFETY INTERLOCK ASSEMBLY	OPSIA-1
38	TRIGGER PINS	OPB-70
39	CROSSBAR SCREW	OPB-22
40	ACORN NUT FOR YOKE PIN	OPB-8
41	RUBBER YOKE SPACER	OPB-5
42	YOKE PIN	OPB-70
43	YOKE	OPA-1001
44	DRIP CAP MOUNTING SCREW	OPB-151
45	DRIP CAP COVER	KD-502397
50	MOTOR DUAL SPEED 1.5HP 11:1 TRANS	OPMOTOR/GBTS
51	GEAR BOX 11:1 TRIPLE PLANETARY	KD-503537
53	SPEED SWITCH	KD-911115
54	HUB CAPS	OPV0038
55	SPRING WASHER	OPB-51
56	5" DOUBLE WIDE WHEELS	KD-489702
57	1/2" FLAT WASHER	OPB-29
58	SPRING WASHER	OPB-30
59	13.5" AXLE FOR 5" DOUBLE WIDE WHEELS	OPM-219
60	MAIN MACHINE FRAME	OPA-166
61	APRON MOUNTING SCREW	OPB-96
61a	LOCK WASHER	OPB-32
61b	FLAT WASHER	OPB-96W
62	BUMPER 17" SPECIFY COLOR	OPM-232-17
63	APRON 17"	OPA-169

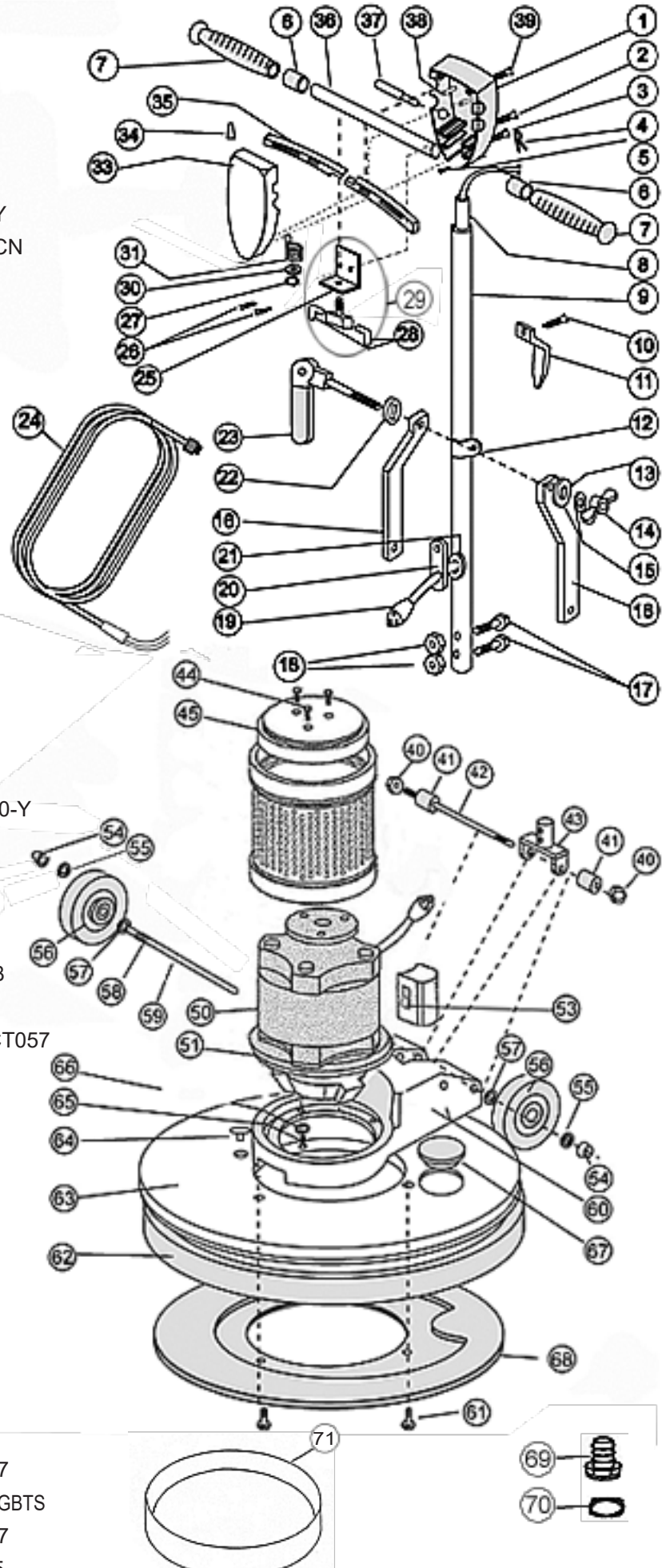

DUST CONTROL PARTS

64	SCRUBBER PLUG	OPB-50
65	MOTOR MOUNTING SCREW	OPB-95
66	SPLIT WASHER	OPB-32
67	APRON PLUG 2"	OPM-218
68	VACUUM PLATE 17"	XM276
	VACUUM PLATE 16"	XM280
69	VACUUM PORT	KD-482401
70	VAC PORT NUT	KD-920629
	HANDLE HOSE ADAPTER (NOT SHOWN)	KA109
	DELUXE PAD DRIVER (NOT SHOWN)	D0116
71	FLOATING DUST RING 17"	KAVACRING
72	DUST SKIRT 16"-17"	KA1500



CENO GROUP • 12221 Carlsbad St., Houston, TX 77085 • 800-710-2366 • Fax: 713-551-8456 • sales@floorsanding.com